

SPARTAN

BRIDGE CRANES 1,6 - 10 t

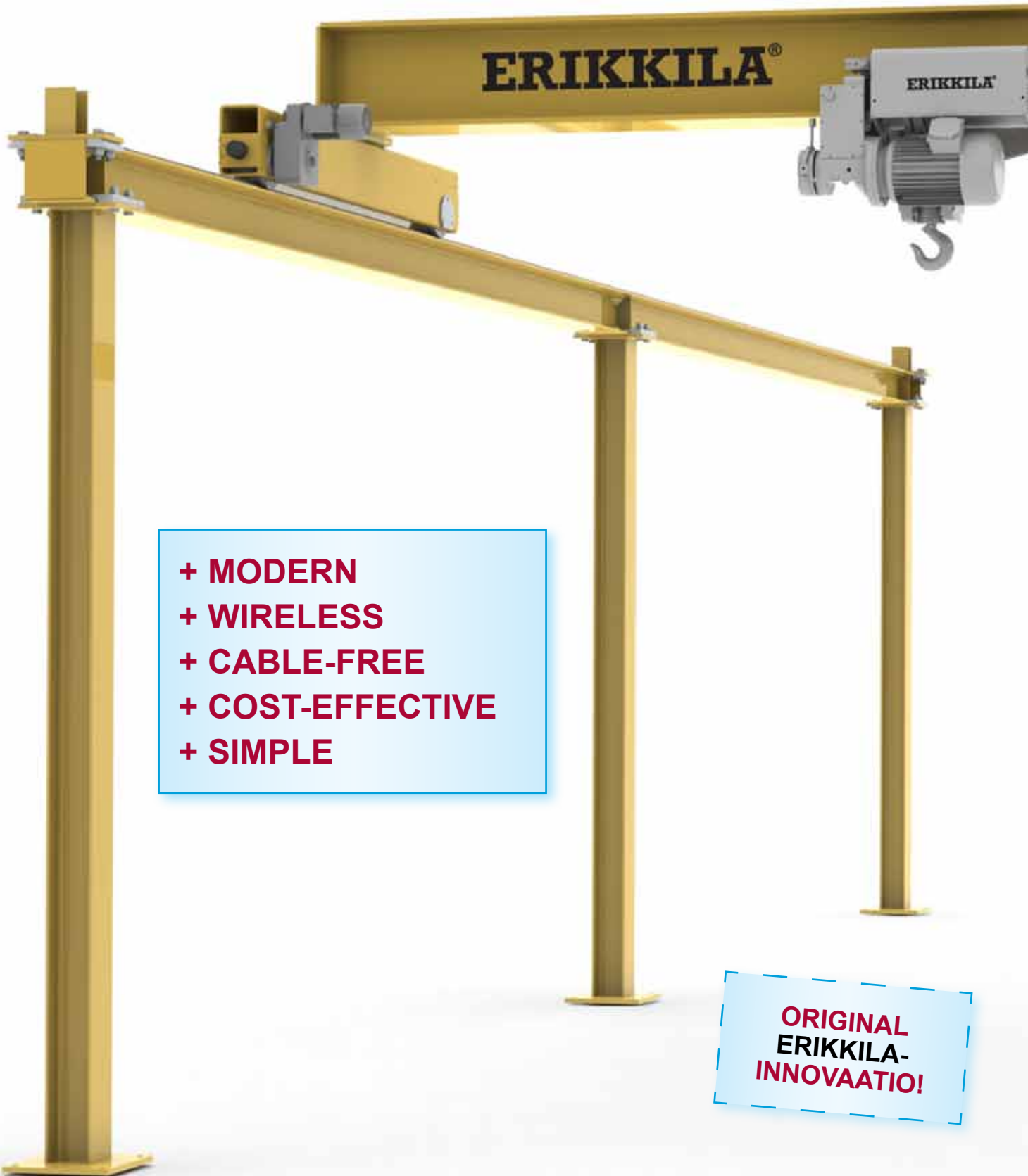

- + MODERN
- + WIRELESS
- + CABLE-FREE
- + COST-EFFECTIVE
- + SIMPLE

**ORIGINAL
ERIKKILA-
INNOVAATIO!**

WHAT IS **SPARTAN** BRIDGE CRANE ?

IT IS A MODERN AND SIMPLE BRIDGE CRANE, WITH
WIRELESS CONTROLS AND **CABLE-FREE POWER SUPPLY**
- AS A STANDARD !

WIRELESS CONTROLS



CABLE-FREE POWER SUPPLY WITH ENCLOSED CONDUCTOR BARS



AVAILAVLE WITH WIRE ROPE AND ELECTRIC CHAIN HOISTS



SPARTAN IN NUMBERS

10 TONNES: LARGEST LIFTING CAPACITY

18 METRES: LONGEST BRIDGE SPAN

2-SPEED LIFTING AND MOVEMENTS

MOVEMENT MOTORIZED TO 6 DIRECTIONS

7 EASY STEPS TO YOUR OWN CRANE



LIFTING CAPACITY 1,6 to 10 TONNES
= Suitable for *all work shops and factories*, requiring heavy lifting.

Examples of usage:

- Machinery maintenance work shops
- For maintaining large factory machines
- Industrial storages and logistic centers
- Heavy vehicle repair shops

CABLE-FREE POWER SUPPLY

= Enclosed conductor bar power supply for both bridge and track as a *standard*.

Advantages on traditional flat cable:

- Less moving parts › *more service free*
- No hanging cables › *less security risks*
- Faster installation › *more cost-effective*

EASY TO BUY & SELL

= Ready-built easy-to-use *price list* based on pre-engineered kit system.

7 easy steps & 7 kits to a crane system:

- | | |
|---------------------|---|
| 1. Bridge kit | 5. Power supply kits |
| 2. End carriage kit | 6. Control kit |
| 3. Track kit | 7. Support columns or welding-in clamps |
| 4. Hoist kit | |

KIT SYSTEM

= Buy in *standardized kits* or as a whole crane system with support columns.

Purchasing options from ERIKKILA:

- Buy kits and manufacturing drawings › *manufacture steelwork locally*
- Buy whole bridge crane system › *convinient and easy*

AVAILABLE OPTIONS

= Increase cranes' *productivity and safety*.

Options include:

- Automatic placing & return home
- Traditional pendant controls for backup
- Multiple bridges on same tracks
- Crane cabin for heavy duty work

LESS CONSTRUCTION WORK NEEDED

= *Easier and faster installation* on-site thanks to support columns and all-bolt connections.

Advantages:

- Easy to move if needed
- No need for large construction work

CRANES UP TO 100 TONNES

= Large cranes always *tailored for customer*.

Other industrial cranes available:

- Portal, semi-portal and gantry cranes
- Automated robotic cranes with over 20 years of experience !

ERIKKILA®

PASSION IN CRANES

[Finland] Sales and Factory
ERIKKILA OY

Masalantie 225
FI-02430 MASALA

T: +358 9 2219 0530

F: +358 9 297 5021

E: sales@erikkila.com

[Estonia] Sales and Factory
OÜ Eesti Kraanavabrik

Tähetorni 21 A
EE-11625 TALLINN

T: +372 6755 070

F: +372 6755 071

E: kraana@erikkila.com

[Russia] Sales Office
OOO Erikkila

Ul. Vozrozhdenia 31 A, Office 204
198188 ST. PETERSBURG

T: +7 812 332 2843

F: +7 812 332 2843

E: ooo@erikkila.com

[Latvia] Sales Office
ERIKKILA SIA

Margrietas iela 7-38
LV-1046 RIGA

T: +371 678 522 28

F: +371 678 522 29

E: sales.lv@erikkila.com

[Lithuania] Sales Office
ERIKKILA UAB

Meistrų st. 8A
LT-02189 VILNIUS

T: +370 5 239 93 63

F: +370 5 239 93 60

E: sales.lt@erikkila.com

[Germany] Sales Office
ERIKKILA Deutschland

ERIKKILA OY
Reisholzer Werftstraße 76
D-40589 DÜSSELDORF

T: +49 211 5426 0080

F: +49 211 5426 0099

E: sales.de@erikkila.com

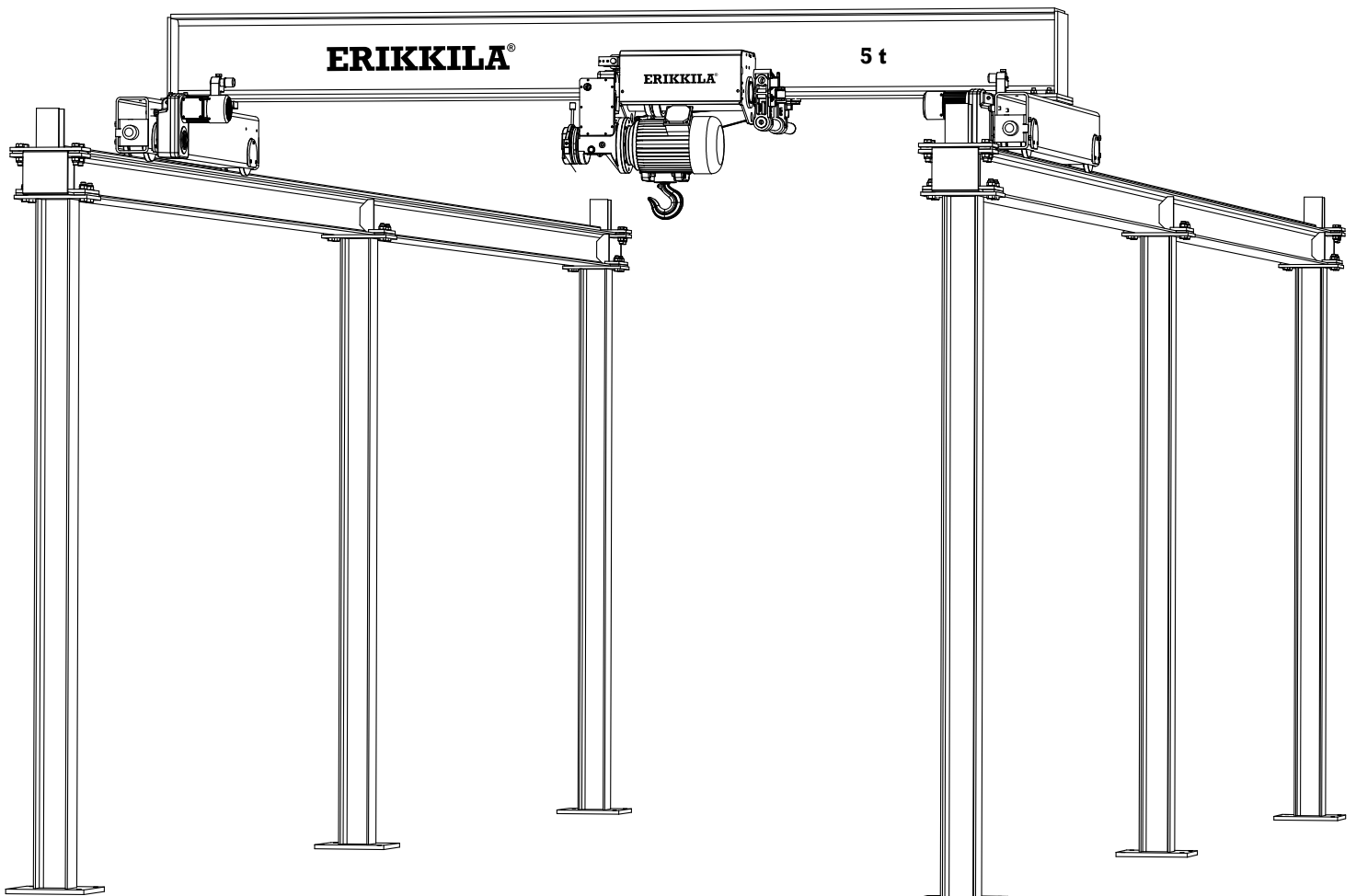

www.erikkila.com